

1 Zeichne jeweils die Symmetrieachse ein.

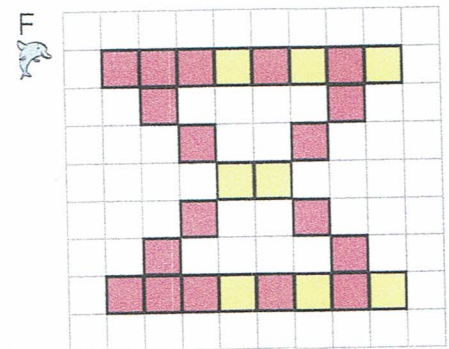

2 Mia hat Symmetrieachsen gezeichnet. Überprüfe.

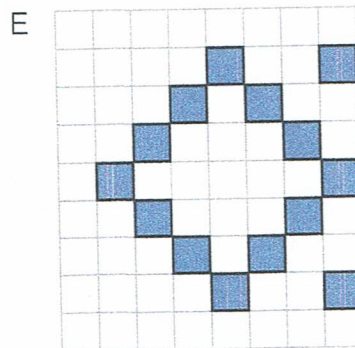
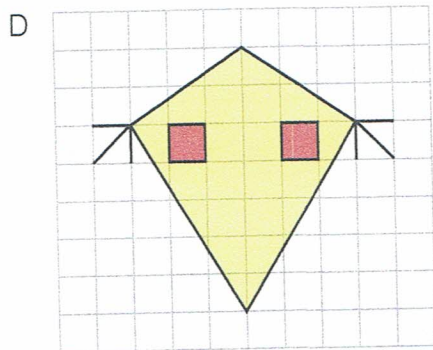
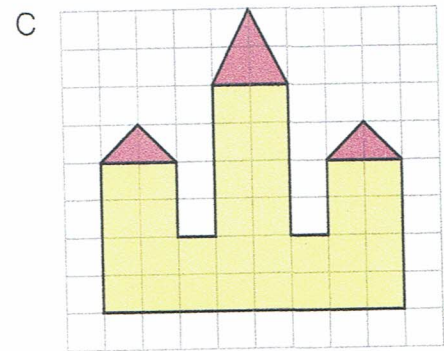
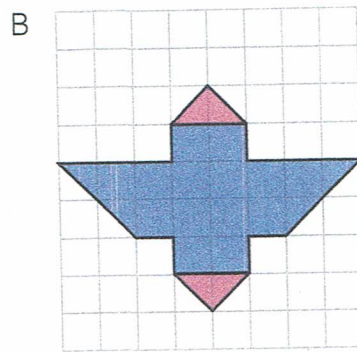
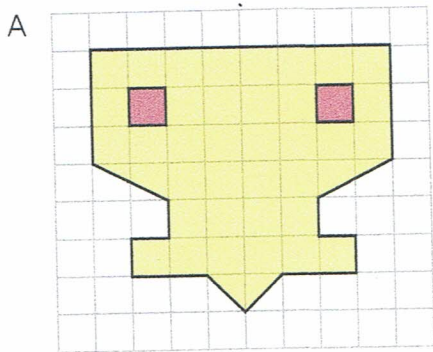
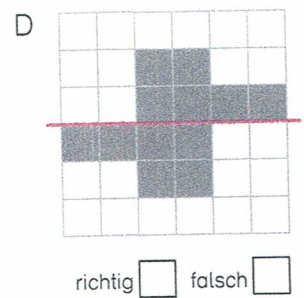
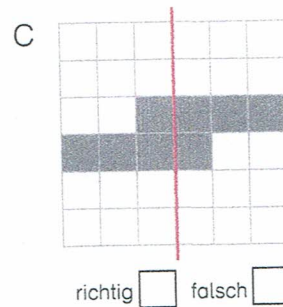
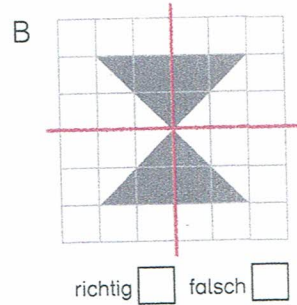
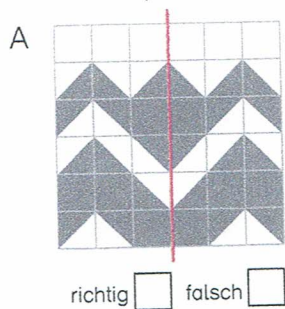

3 Findest du alle 17 Symmetrieachsen? Zeichne sie ein.

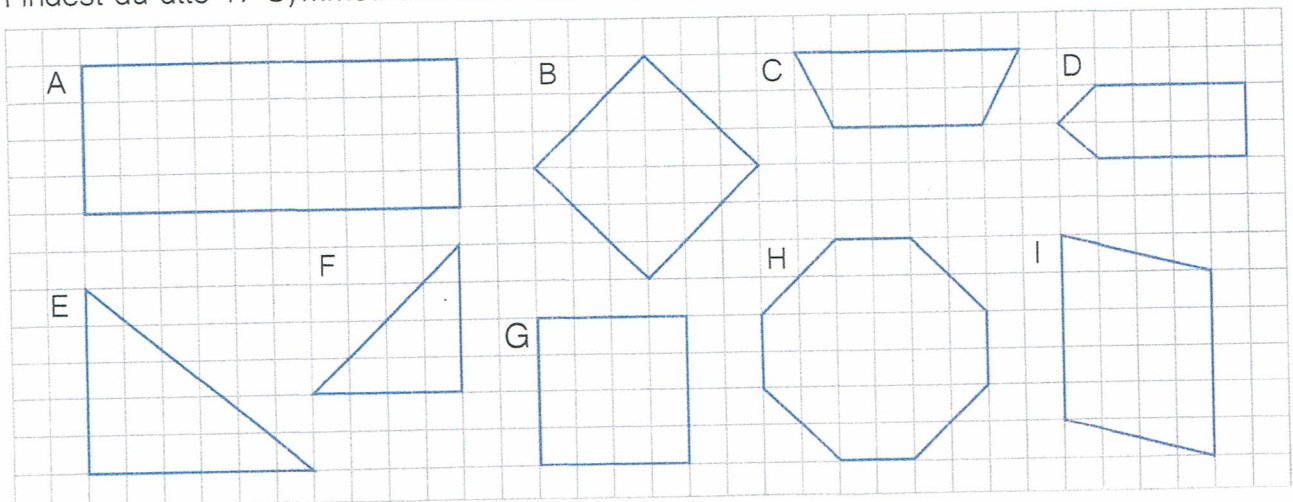

# Punkte und Figuren an zwei Achsen spiegeln

1 Spiegle die Punkte an der Symmetrieachse und nummeriere sie.

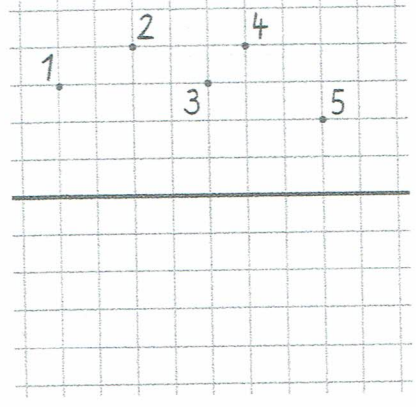
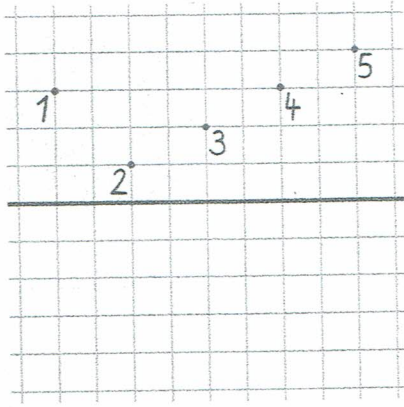
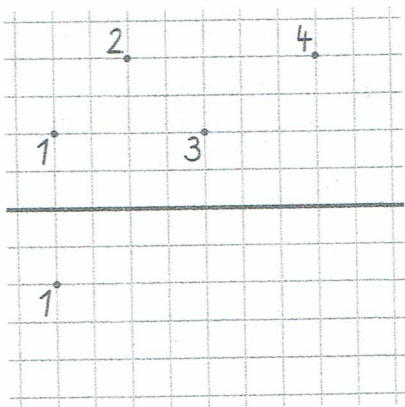

2 Spiegle die Punkte an den Achsen und nummeriere sie.

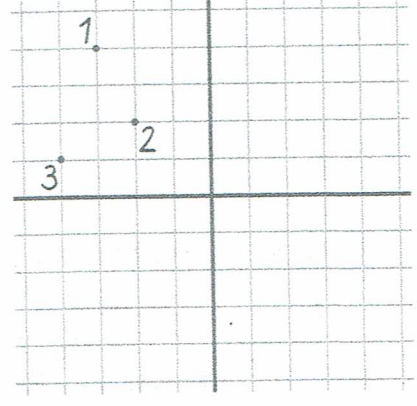
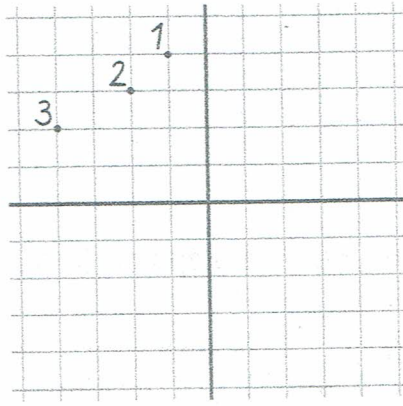
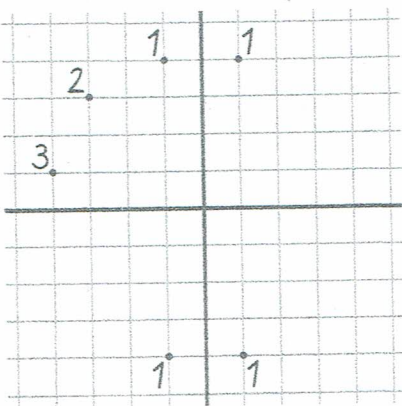

3 Spiegle die Punkte an den Achsen. Nummeriere und verbinde sie.

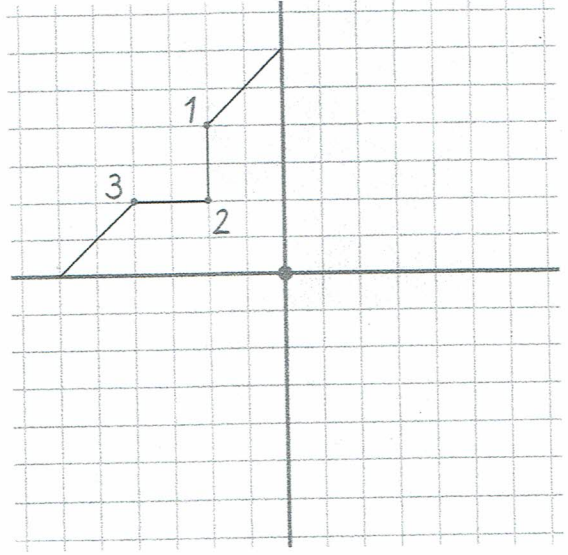
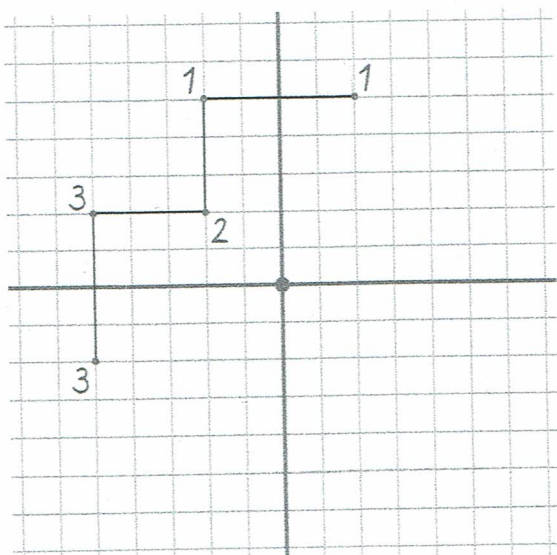

# Figuren drehen

- 1 Schneide die Figuren aus. Lege eine Figur links oben in das Achsenkreuz und zeichne den Umriss der Figur. Dann bewege die Figur um den Drehpunkt und zeichne drei weitere Umrisse.

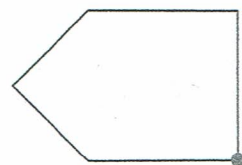
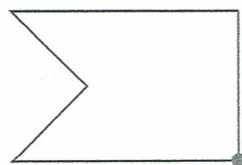
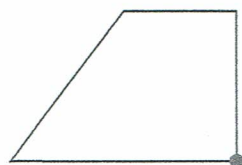
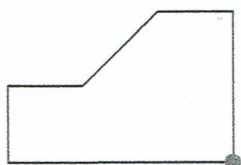
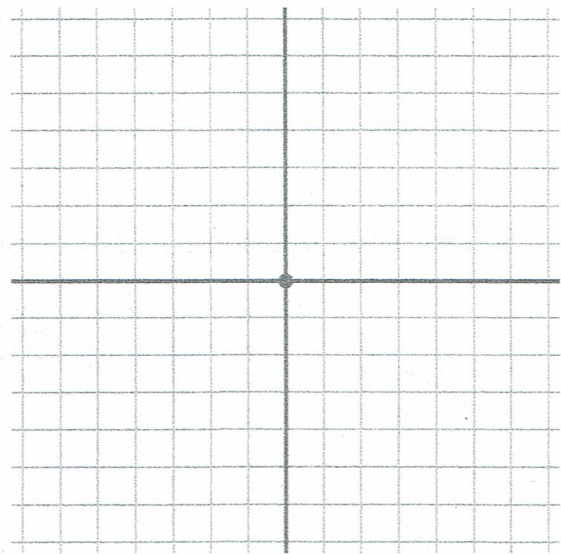
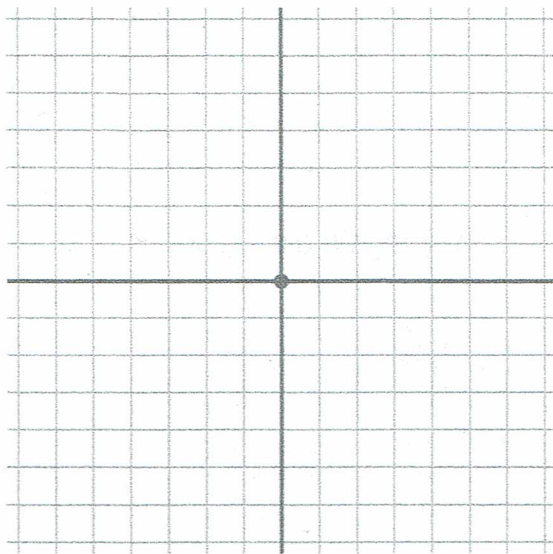
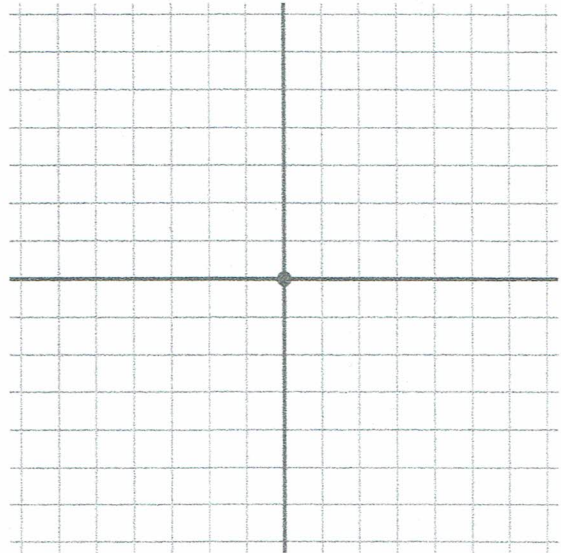
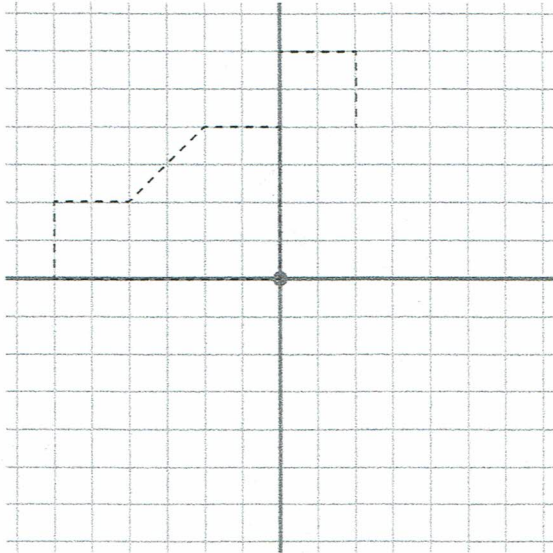

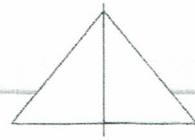

1 Ergänze die Figuren durch 4 Drehungen zu drehsymmetrischen Figuren.

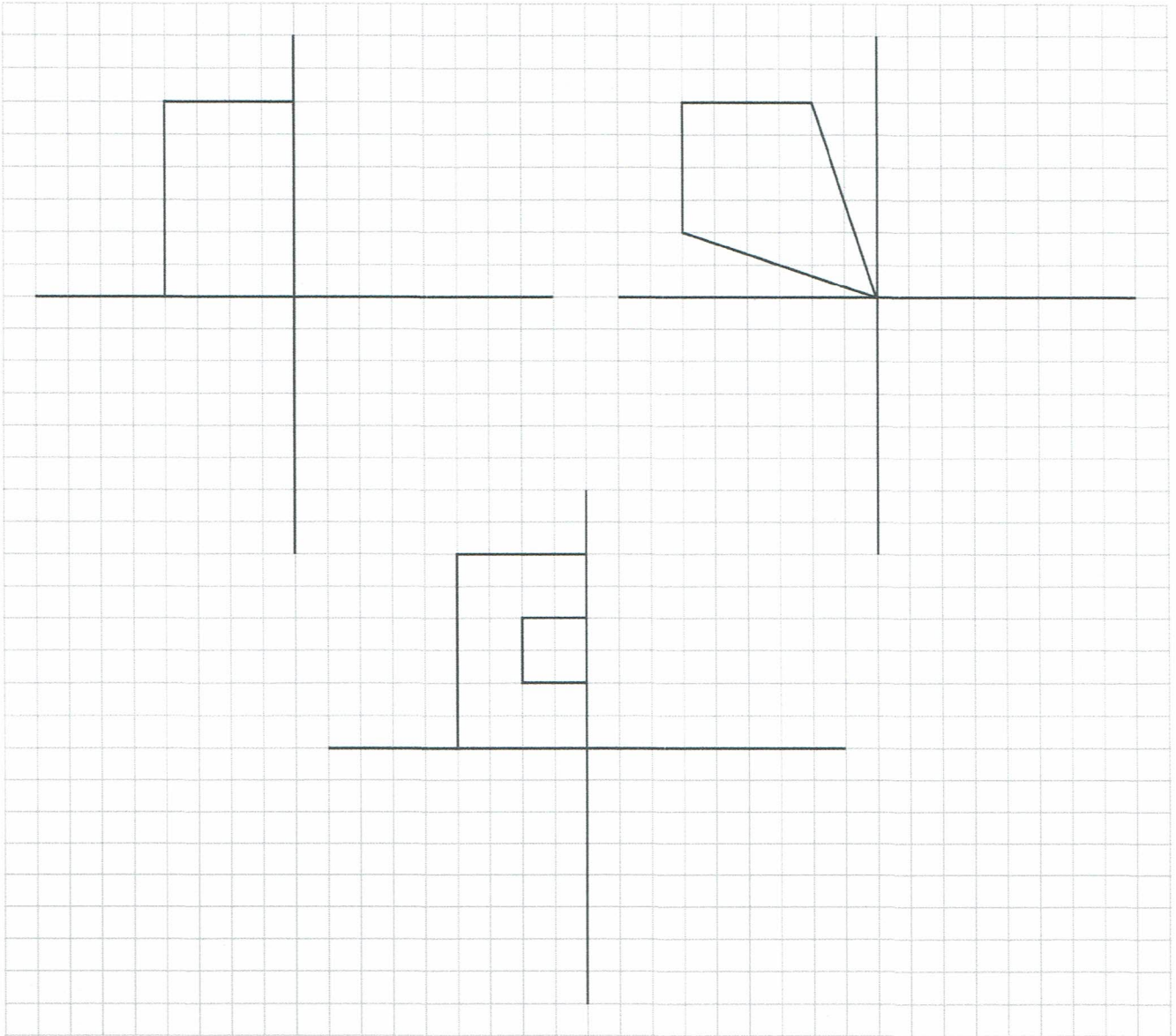

2 Zeichne eigene drehsymmetrische Figuren.





# KV 95: Drehsymmetrische Figuren erzeugen

## Anleitung

1. Zeichne dieses Dreieck auf einen Karton und schneide es aus.

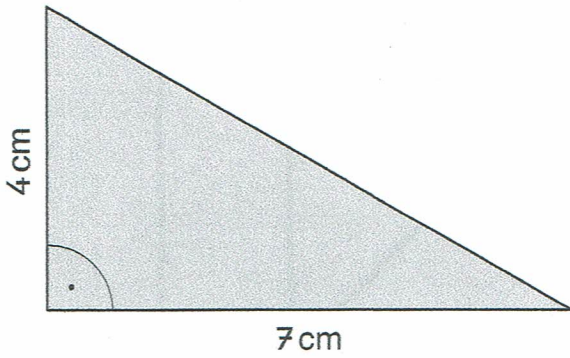

2. Verwende das ausgeschnittene Dreieck als Schablone und zeichne solche Windräder in dein Heft oder auf ein Blatt.

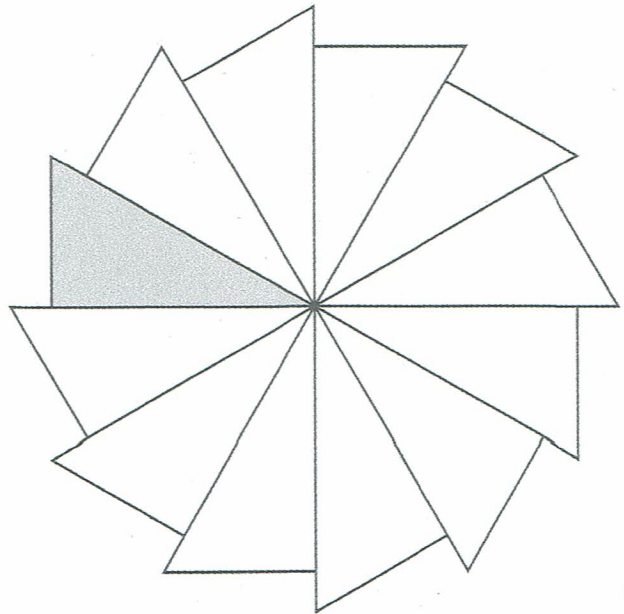
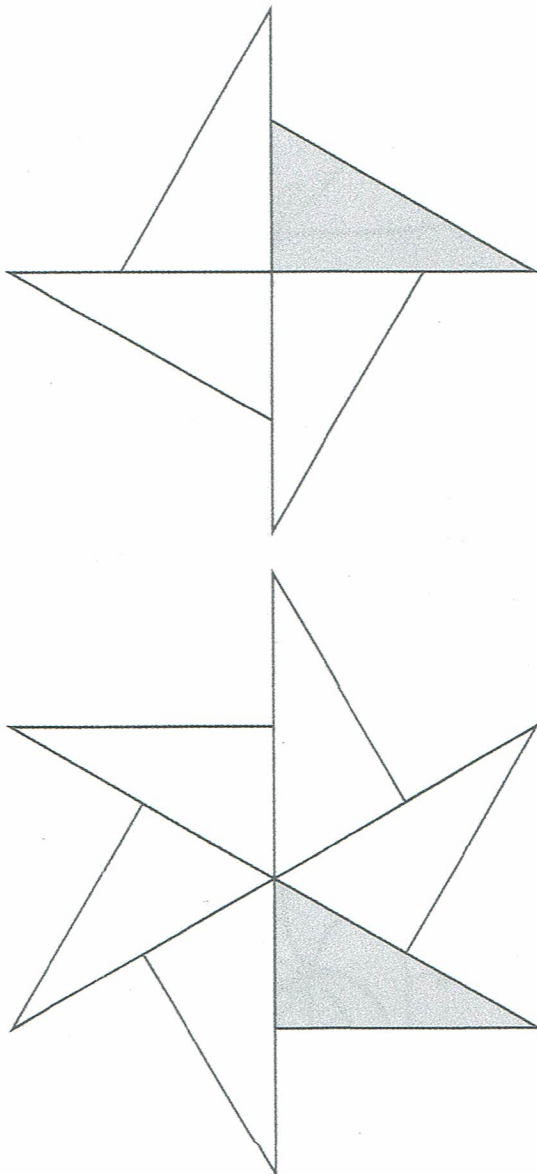

© 2013 Cornelsen Schulverlage GmbH, Berlin.  
Alle Rechte vorbehalten.



1 Ergänze die Teilfiguren jeweils zu einer drehsymmetrischen Figur.

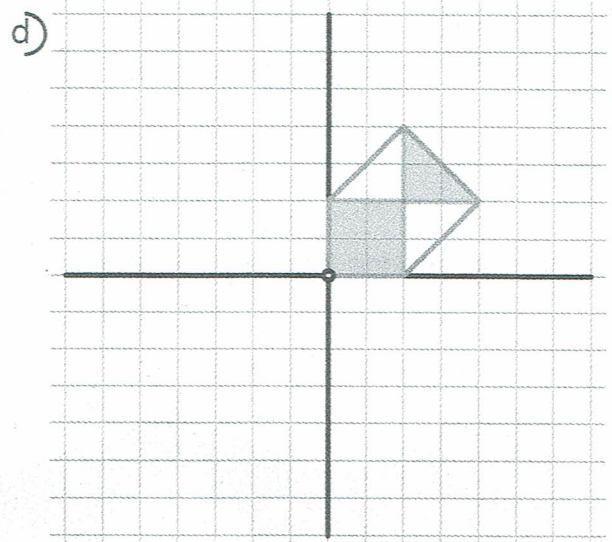
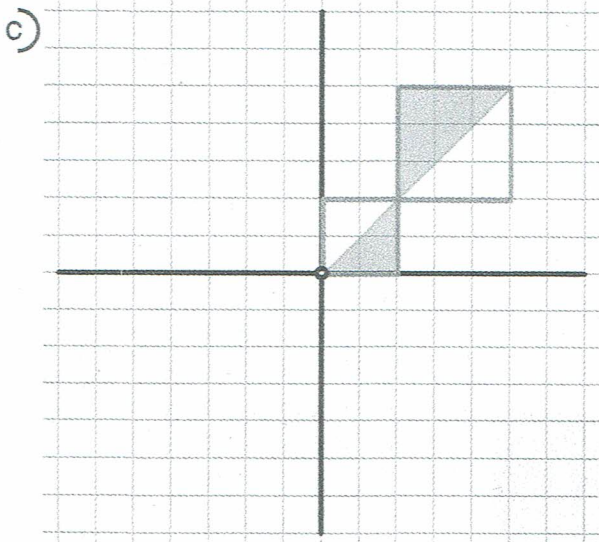
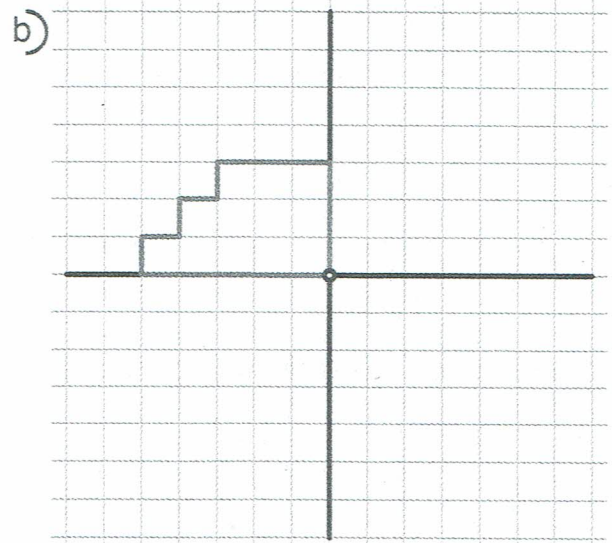
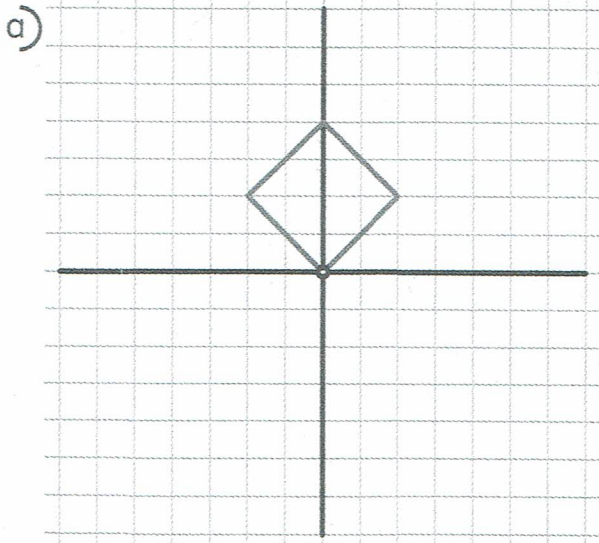

2 Färbe die Figuren so, dass sie drehsymmetrisch sind.

